



Picture: HLK/Kerstin Hainzl

Partial view of the tradition-steeped University of Vermont.

UNIVERSITY OF VERMONT / KONVEKTA

Efficiency solution for STEM project

The University of Vermont \$104 million investment in a new Science Technology Engineering and Mathematics (STEM) Complex, will feature the design and development of state-of-the-art 21st century learning and research facilities, with the goal of attracting and retaining world-class students and faculty. Sustainable building design standards include a commitment to LEED Silver certification or better, for the more than 250,000 square feet of new construction and renovation projects. The integration of Konvekta's intelligent, highly efficient, energy recovery system into the design of the STEM Complex heating and cooling systems has proven to be a critical element in achieving the high efficiency standards necessary for the development of the state-of-the-art STEM facilities.

Several Universities and Educational institutes were visited by HLK facility manager Kerstin Hainzl on her tour of Konvekta USA systems. The first stop was the State University of Vermont (also called UVM after its original Latin based name Universitas Viridis Montis) located in northwestern Vermont.

Invest in quality

WUVM is a member of the Ivy League, and with more than 10,000 Students, is also the largest higher ed institution in the state of Vermont. The University has an excellent reputation in many areas of study and research including the fields of Biology, Environmental, Agricultural

and Life sciences, with plans to invest roughly \$100 Million over the next few years, in the construction and renovation of their STEM-Complex facilities. The existing buildings where the Chemistry, Physics, Engineering, Mathematics and Statistics departments as well as IT are located, are outdated and require renovation in order to comply with current and future guidelines. UVM's objectives include supporting the needs of STEM teaching and research, through the construction of modern Laboratories, Classrooms and an Office complex. The intended building projects will be split into three distinct phases, and will be carried out over a time frame of four years. The first phase encompasses the construction of the Discovery Build-

ing, a highly modern teaching and research laboratory, while the second phase includes a new Innovation Building, along with a Classroom/Office building. The third phase comprises a renovation of the Votey Building. In alignment with the UVM policy of "Environmental Design in New and Renovated Buildings", the STEM Complex projects will be designed to meet or exceed a LEED Silver standard. In order to meet this standard, the building complex should use 59% less energy for heating and cooling than a conventional building of similar size. Attainment of this level of efficiency, required a design strategy which included both optimal thermal insulation and an intelligent high efficiency energy recovery system. As a



The University of Vermont is going to carry out comprehensive renovations or resp. new construction projects over the next few years.

result of industry leading efficiencies, and a proven track record of performance, the perfect solution for this project was Konvekta.

Energy efficiency requirements

Current ASHRAE guidelines require a minimum overall energy recovery system effectiveness of 50 %.

Konvekta has a recognized history of designing and installing energy recovery systems that exceed the ASHRAE guidelines, as well as the higher European Eco-design standards which currently demand a thermal efficiency of 68% in Run Around Energy Recovery Systems.

Details about Konvekta’s energy recovery system

The Konvekta closed circuit energy recovery system located in the mechanical penthouse of the STEM facility, includes two fully redundant

integrated steam heat exchangers, and serves 2 zones of supply air and 2 zone of exhaust air. The University has a central steam plant with two boilers, which delivers heat to campus buildings via a network of underground piping. This network also serves the new STEM building, leading to the use of steam as a supplemental heat source for the Konvekta system. In the event of a failure of one of the steam heat exchangers the backup heat exchanger will be able to provide 100% of the required capacity on a winter design day.

It has been our observation that when using steam instead of hot water, controllability of the heating function can be more difficult to achieve due to the high level of oscillation and non-linearity of the temperature curves. The Konvekta solution can provide a decisive benefit in the control of a steam heat exchanger based on the unique ability of the intelligent

Konvekta System Controller to learn the steam oscillation pattern and develop a heat exchanger performance map. The result is a very stable, yet responsive heating control loop, a fundamental requirement of efficient system operation.

Typically the supply air is heated to 55 deg. F. , although as shown in the Graphic 2 diagram, this can change based on demand. The discharge air is then re-heated as needed using a zone re-heat coil, to achieve the temperature setpoint of the individual building room or zone.

The UVM winter outdoor air temperature used for system design purposes was -19 deg. F. As a result of the potential for extreme winter conditions in Burlington, Vermont, a snow melting function was incorporated in the design of the energy recovery system, which included a pre-heat coil located in the outside air intake section

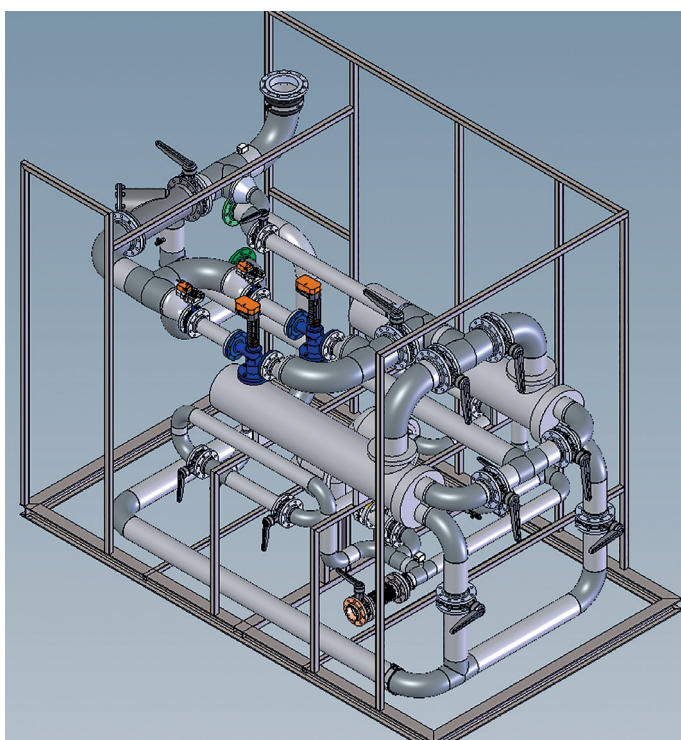

Picture: Konvekta

Graphic 1
Steam converter



STATEMENT ...

**... from Rudolf Zängerle, Ph.D.,
Managing Director, Konvekta USA Inc.,
on the UVM Project**

Konvekta USA is a subsidiary of the Swiss producer Konvekta AG and produces highly efficient energy recovery systems for ventilation systems in large building projects. Now, after 7 years in the American market, we have installed over 60 energy recovery systems in the USA and Canada. Medical facilities, chemical production plants and research laboratories in renowned Universities, Hospitals and the Pharmaceutical industry have all realized significant benefits as a result of their decision to install our high efficiency energy recovery systems.

The University of Vermont was also searching for a superior solution for their requirements in their new research building STEM (Science, Technology, Engineering and Mathematics). The technology provided by Konvekta was an ideal match for the UVM sustainability and reduction of CO₂ emissions goals. The Konvekta solution will reduce the heating requirements of the new UVM research building by more than 80% annually.

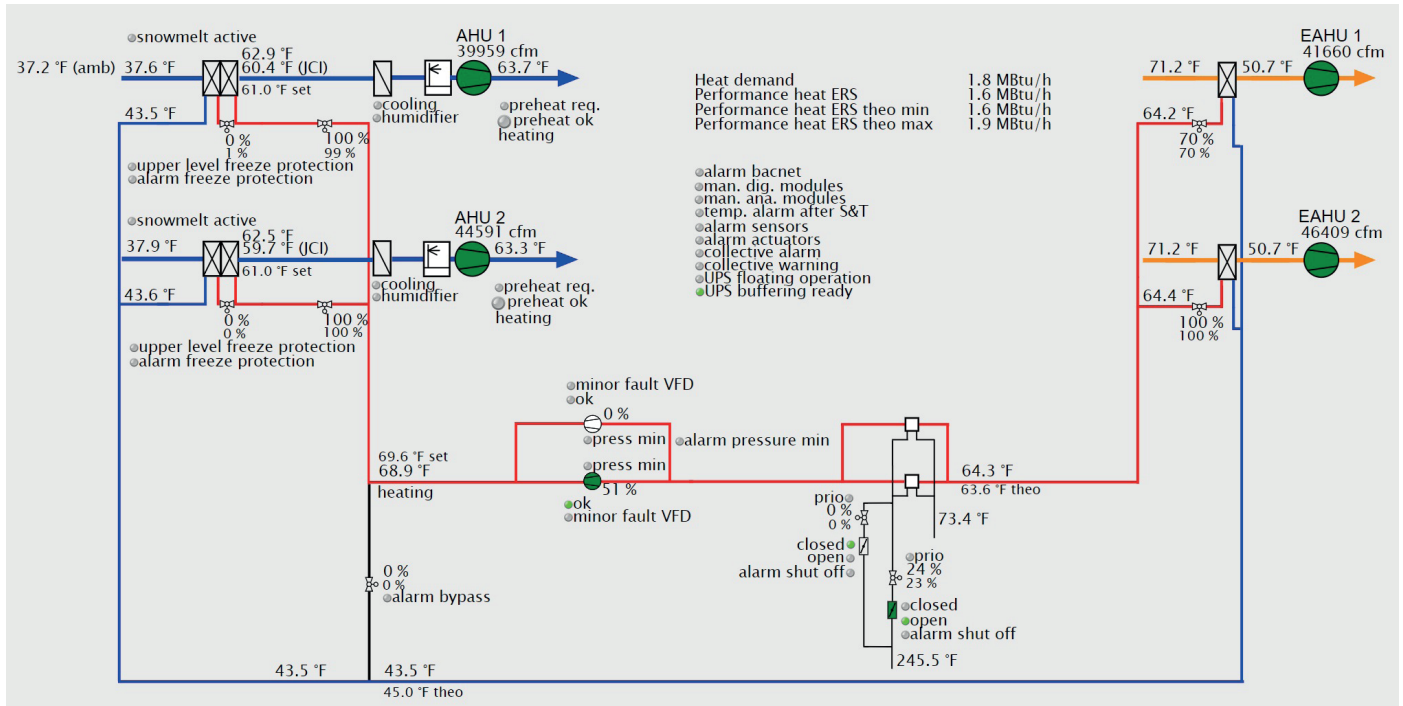

Graphic 2: Schematic representation of the UVM system.

of each air handling unit, upstream of the air filters. A primary function of the pre-heat coil is for the purpose of de-icing the outside air and melting any snow drawn into the outside air intake section of the air handling unit.

Focus CO₂ reduction

At UVM a primary objective of energy efficiency is the reduction of CO₂ emissions. The Konvekta energy recovery system will reduce UVM’s annual carbon emissions by approx. 1,650 MeTCO₂ each year. An example, for illustration: A car emits, on average, 0.9 lbs. of CO₂ per mile. The savings represented by the STEM energy recovery system are equivalent removing 353 cars from the highways!

The overall annual effectiveness of the STEM energy recovery system is approx. 85 %, therefore only 15% of the total energy requirement is supplied by the central plant. The Konvekta

system provided the contractor with an ideal solution by maximizing the annual energy savings and CO₂ reduction at a cost allowing for a quick payback of the initial investment. Thanks to the decision to install a Konvekta high efficiency energy recovery system, the CO₂ emissions are half of what they would have been as compared to other conventional systems on the market. Summer exhaust air temperatures between 73 and 75° F allow for pre-cooling of the outside intake to 80° F at the summer design condition, significantly reducing the peak cooling demand. The overall result is a clear win-win situation, with industry leading energy and CO₂ savings in addition to a system that pays for itself in a short period of time.

Optimal heating performance

The STEM building has a peak heating demand of approx. 1.5 MW. The system performance was calculated based on a design decision to

utilize a 30% propylene glycol solution, which is more viscous, and possesses a lower thermal conductivity than an ethylene glycol solution. Propylene glycol is heavily used in the food industry and is nonpoisonous, whereas ethylene glycol can be highly toxic when ingested. The decision to utilize a propylene glycol solution did result in a reduced heat recovery performance while also requiring more pumping energy than would have been the case with an ethylene glycol solution.

Energy values and summary

When it comes to energy recovery, Konvekta systems have an exceptional history. The STEM facility is the beneficiary of Konvekta’s extensive design and implementation experience, with a total energy recovered of over 6,000,000 kWh per year! After accounting for the energy required to operate the closed loop pump of 275,000 kWh per year (<5% of the recovered energy), the net benefit achieved by Konvekta’s high performance system, results in a very high return on investment for UVM. Additionally, the return on investment guaranteed by Konvekta is significantly higher than would have been the case with a conventional energy recovery system. Currently we are in the operational optimization phase. Detailed data will be available in about one year.



External view of the ventilation unit including the piping for the high performance closed circulation system from Konvekta.



Internal view of the ventilation unit. On the right of the picture you can see one Konvekta heat exchanger.



Digesters in the research laboratories for chemical tests. The exhaust air is drawn upwards and directly integrated into the exhaust channel. This means the contaminated or dangerous exhaust air is immediately exhausted.

INFO

About the University of Vermont

Foundation: 1791
Location: Burlington, Vermont
Country: United States of America
Trusteeship: State Admission quota: 69 % (2016)
Student numbers: 11,898 (2016)

About the UVM project

Client: University of Vermont
Konvekta headquarters in the USA: Princeton, New Jersey
Commissioning of energy recovery system: April 2017
Scope of delivery Konvekta: Closed circulation system with 2 supply air zones and 2 exhaust air zones (with integrated back-up heating)
Max. volume of air in the installed systems: 148'300 cfm
Completion date of the entire building complex: planned for summer 2019



On a tour of the University complex: (f.l.) Brad Carpenter, DAC Sales, Rudolf Zängerle, Ph.D., Managing Director Konvekta USA Inc., Robert B. Vaughan, Dave Blatchly and Lynn Johnston, all University of Vermont.

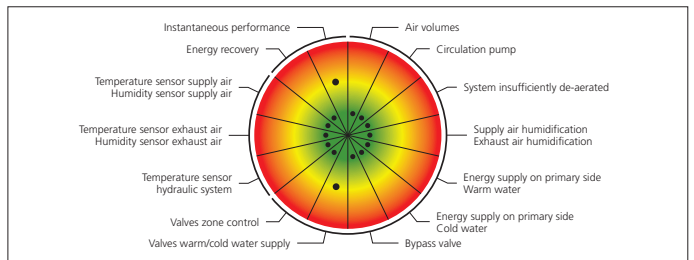

Picture: Konvekta

The UVM project also benefits from a Konvekta System-Controller "Eiger" with continuous performance monitoring, providing maintenance personnel with easy to interpret diagnostic information. When a slight disturbance occurs the needle goes from the green to the yellow sector, and when a serious disturbance occurs the needle goes into the red sector, alerting the operator of a need to take corrective action.

Keep an eye on your energy savings!

New Generation System Controller **Eiger** from Konvekta is the only software that continuously monitors the operation and efficiency of the energy recovery system. With high-performance energy recovery systems from Konvekta, recovery rates of 70-90% and capital returns of 20-60% can be achieved.

Guaranteed and without any risk!

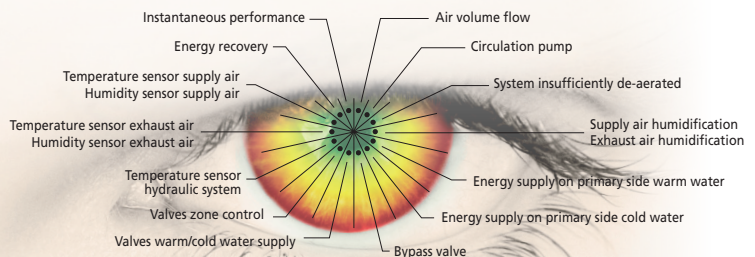

Konvekta USA Inc.
 US-Princeton, NJ 08540
 info@konvekta-usa.com
konvekta-usa.com



Convekta GmbH
 DE-88239 Wangen
 info@convekta.de
convekta.de



Konvekta Shanghai
 CN-Shanghai 200050 China
 info@konvekta.ch
konvekta.ch



Konvekta AG
 CH-9015 St.Gallen
 info@konvekta.ch
konvekta.ch